

Technical Manual

Technical Manual

Technical Manual

Technical Manual

Technical Manual

Technical Manual

Technical Manual

Technical Manual

Technical Manual

Technical Manual

Technical Manual

Technical Manual

Technical Manual

Technical Manual

Technical Manual

Technical Manual

Technical Manual

Technical Manual

Technical Manual

Vacuum Jacketed Pipe



Member of the
Acme Cryogenics
Group

800-966-6167 • www.vjpipe.com

Introduction

Quality Cryogenics designs, manufactures and installs stainless steel super insulated Vacuum Jacketed Piping (VJP) systems used for the transfer of liquid nitrogen, oxygen, argon, natural gas, carbon dioxide and helium. Each VJP system is custom designed to meet the requirements of the application while keeping the system economics within budget.

Quality Cryogenics' engineering staff designs each Vacuum Jacketed Piping system to meet users' safety, flow and other application requirements.



Our manufacturing team builds Vacuum Jacketed Piping using trained personnel and certified welders. Our technicians are highly trained in vacuum technology, insulation techniques and VJP system testing.

Our field service staff has years of cryogenic application experience and can expertly perform site

surveys and on-site modifications.

Quality Cryogenics is located just north of Atlanta, Georgia and is easily accessible via major interstates. We are a member of the Acme Cryogenics Group of companies. Together we have the resources and flexibility of three east coast manufacturing facilities. We have over 25 years of combined experience in the cryogenic piping industry. Our commitment to quality has made Quality Cryogenics the preferred Vacuum Jacketed Piping supplier of major gas producers, liquid distributors and cryogenic equipment users worldwide.

About Vacuum Jacketed Pipe

Quality Cryogenics uses stainless steel pipe in the manufacturing of its Vacuum Jacketed Pipe. Vacuum Jacketed Pipe contains an inner line for the transfer of cryogenic liquids and an outer vacuum jacket. The vacuum annular space consists of a multi-layered insulation with an extremely low vacuum level of 9 microns or less. Vacuum Jacketed Pipe is 50 times more effective than conventional foam insulated copper in preventing heat leak to the inner line, and our vacuum lasts for more than 10 years in the field.

With our extensive quality control and the use of a helium mass spectrometer test for every welded joint, Quality Cryogenics' VJP systems enjoy a long field life.

Quality Cryogenics prefers the use of inner line expansion joints. With the use of stainless steel inner line expansion joints, the pipe supports for our Vacuum Jacketed Pipe need not compensate for the thermal expansion of the inner line (3.86 in/100 ft for LN₂).

For lengths of jacketed pipe over 40 feet in length, it is necessary to divide the pipe into individual spool sections. Quality Cryogenics offers two options: a bayonet joint or a field joint coupling. A bayonet is a mechanical joint used for lines that can be dismantled and assembled easily while maintaining a low heat inleak at the joint. These close tolerance bayonets consist of a male bayonet that couples with the female bayonet such that no liquid will flow past the seal, and the silicon O-ring finishes the seal. The flanges are held in place by a quick release V-band clamp. See Appendix B. For another type of connection, Quality Cryogenics offers a vacuum insulated field joint coupling. This joint begins with a welded coupling between the spools, then is wrapped with our super-insulation and evacuated to our standard vacuum level. The assembly consists of an outer sleeve that is field welded to collars attached to the VJ Pipe spools on either side.

Sizing Guide

Quality Cryogenics manufactures Vacuum Jacketed Pipe to satisfy our customers' specifications and specific needs. Quality Cryogenics designs and fabricates both rigid and flexible VJ Pipe for liquid nitrogen, oxygen, liquefied natural gas, carbon dioxide, argon, and helium. Inner pipe sizes range from 1/2" to 8" and larger for rigid pipe, and 1/2" to 6" for flexible.

When determining the configuration for your piping layout, remember the constraints imposed by shipping 7.5' x 7.5' x 40' (2.3m x 2.3m x 10.4m) and installation. One must consider these factors when designing spool lengths for fabrication.

Rigid Vacuum Jacketed Pipe Analysis

Inner Pipe Size/material	Jacket Pipe Size/material	Total Weight	Cooldown lb of LN2/ft (Kg of LN2/m)	Heat Leak BTU/Hr/Ft (Watt/m)	Bayonet Heat BTU/Hr (Watt)	Field Joint BTU/Hr (Watt)
1/2" SCH 5 21.3 mm OD 304SS	2" SCH 5 60.3 mm OD 304SS	2.4 lb/ft 3.6 kg/m	0.27 (0.40)	0.32 (0.31)	6.6 (1.9)	5.9 (1.7)
1" SCH 5 33.4 mm OD 304SS	3" SCH 5 88.9 mm OD 304SS	4.2 lb/ft 6.2 kg/m	0.43 (0.64)	0.45 (0.43)	9.1 (2.7)	5.9 (1.7)
1 1/2" SCH 5 48.3 mm OD 304SS	3 1/2" SCH 5 101.6 mm OD 304SS	5.0 lb/ft 7.4 kg/m	0.64 (0.95)	0.56 (0.54)	13.3 (3.9)	8.5 (2.5)
2" SCH 5 60.3 mm OD 304SS	4" SCH 5 114 mm OD 304SS	5.8 lb/ft 8.6 kg/m	0.80 (1.19)	0.75 (0.72)	20.9 (6.1)	11.5 (3.4)
3" SCH 5 88.9 mm OD 304SS	5" SCH 5 141 mm OD 304SS	9.8 lb/ft 14.6 kg/m	1.51 (2.25)	0.98 (0.94)	28.1 (8.2)	29.4 (8.6)
4" SCH 5 114 mm OD 304SS	6" SCH 5 168 mm OD 304SS	12.0 lb/ft 17.9 kg/m	1.96 (2.92)	1.28 (1.23)	66.1 (19.4)	35.3 (10.3)

Sample Layout

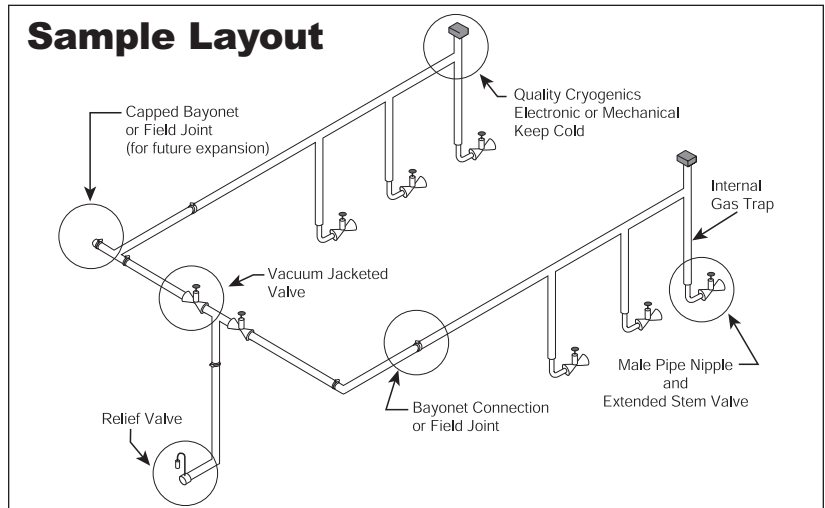

Quality Cryogenics Systems Design Checklist

- ✓ Determine basic routing of the nitrogen system, such as bulk tank location, equipment location, and piping elevation.
- ✓ Provide an isometric sketch to clarify piping configuration. Quality Cryogenics will then provide isometric Autocad drawings with dimensions for your verification. Quality Cryogenics can provide any assistance needed in determining layout or dimensions.
- ✓ Size the pipe and components based on current flow rates, while providing for any future expansion. Consult Quality Cryogenics for assistance.
- ✓ Identify liquid demands to help Quality Cryogenics determine the components needed to maximize your piping system's efficiency.
- ✓ Highlight any installation points of interest, such as wall penetrations, close quarters, existing fixtures, drop ceilings, etc.
- ✓ Determine any installation restrictions for length with regards to access for pipe and assembly.

Typical Attributes For Your Vacuum Jacketed System...

- ◆ Bayonet couplings for ease of installation
- ◆ Field welded couplings for lower heat inleak and material costs
- ◆ 1" to 2" headers for main or high usage branch runs
- ◆ 1/2" drops to equipment
- ◆ Vacuum jacketed in-line valves for branch isolation during shutdown or repair
- ◆ DV-6R for monitoring vacuum level of VJ Pipe
- ◆ Internal gas traps prevent frosting of standing end connections when not in use
- ◆ System relief valve for line safety (if located indoors, it must be piped to exterior)
- ◆ Quality Cryogenics Electronic or Mechanical Keep-Colds maintain cold temperatures at the main header and use points
- ◆ Capped bayonet or field joint coupling for future expansion
- ◆ Extended stem cryogenic control valves (usually end use conditions)
- ◆ Vacuum Jacketed Flexible Pipe for use with vibrating equipment or minimizing alignment problems

Appendix A

Vacuum Insulation

Quality Cryogenics uses alternating layers of fiberglass paper and metal foil wrapped around the inner line, and gettering material to maintain long term vacuum integrity. Vacuum integrity is assured by the use of a helium leak detection sensitivity of 10^{-9} cc/sec on all welds. The vacuum is sealed at 9 microns or less. With the use of non-conductive spacers for the inner line, the Vacuum Jacketed Pipe effectively discourages conduction, convection, and radiation heat transfer. The effectiveness of Quality Cryogenics' VJ piping is dramatic in comparison to other conventional insulation.

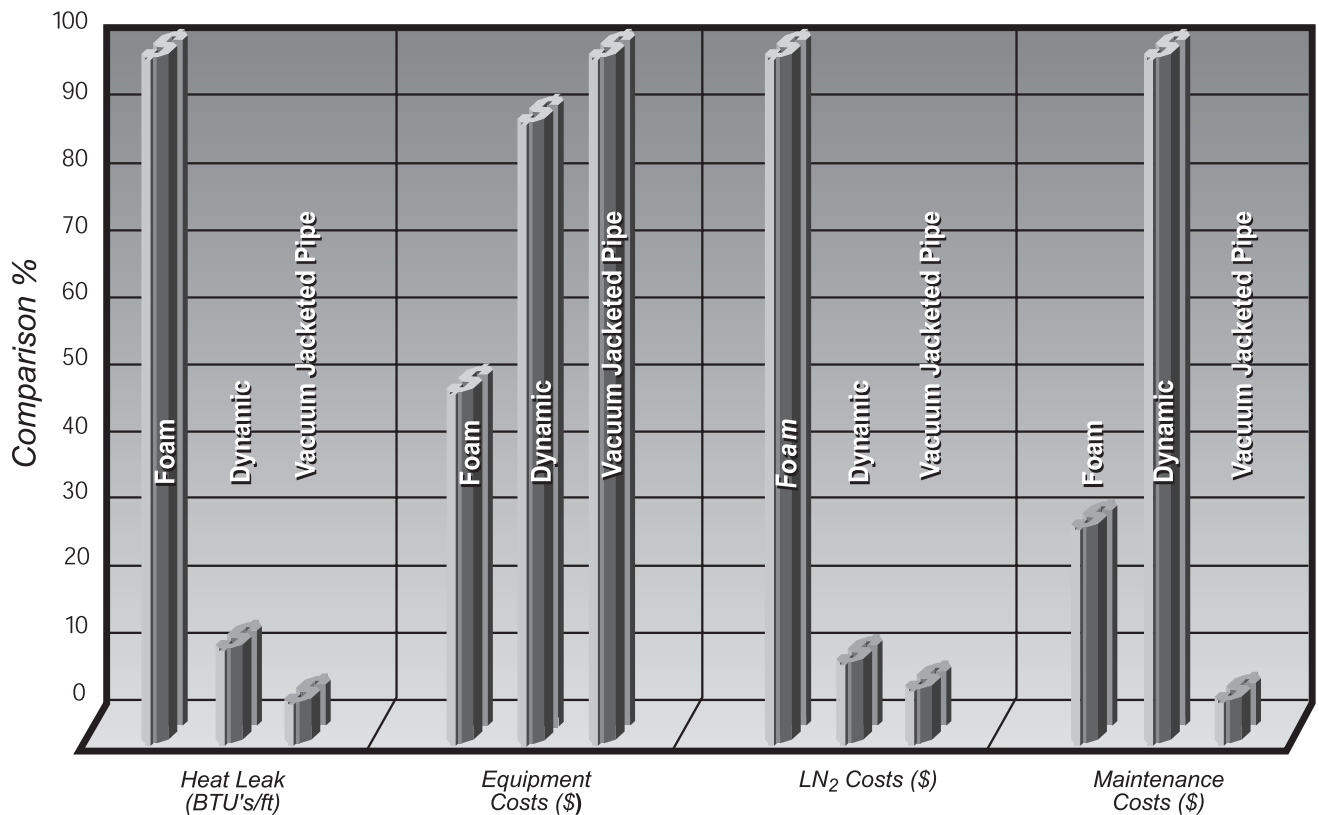

Cost Savings Calculations for Quality Cryogenics VJ Pipe vs. Foam Insulated Pipe

Appendix A

The following example is for 200 feet of 1" x 3" Quality Cryogenics VJ pipe compared with foam insulated 1" pipe. Operating parameters of 24 hrs/day and 365 days/yr are used to indicate a system with a Keep-Cold unit installed.

Example of 1" x 3" pipe

VJ pipe size: 1" x 3"
 Service: Liquid Nitrogen
 Joint type: Quality Cryogenics Bayonet

Input Values	
Heat Loss for VJ Pipe (BTU/ft x hr)	0.45
Heat Loss for Foam Insulated Pipe (BTU/ft x hr)	20
Overall Length of Pipe (ft)	200
Heat Loss for Joints in VJ Pipe (BTU/hr)	9.1
Number of Joints in VJ Pipe	7
Daily Usage (hr/day)	24
Days per Year	365
Heat of Vaporization of Cryogenic Liquid (BTU/lb)	85.6
Cost of Cryogenic Liquid (\$/lb)	0.04
Cost Due to Heat Leak	
\$ per Year for VJ Pipe	\$629.16
\$ per Year for Foam Insulation Pipe	\$16,373.83
\$ Savings per Year for VJ Pipe vs. Foam Insulated Pipe	\$15,744.67

Formulas:

Heat loss/hr = (heat loss/hr/ft of pipe x pipe length) + (heat loss/joint/hr x number of joints)

\$/yr = (heat loss/hr x \$/lb x hrs/day x days/yr) / heat vaporization

Notes:

1. These calculations are to be used to demonstrate the relative efficiency of VJ vs. foamed copper, not to predict actual system losses. Actual system losses include any number of variables not represented by these calculations.
2. These calculations do not include cool down losses.
3. The cost per lb. of the liquid may vary considerably, consult your gas supplier for your cost. (\$0.04/lb = \$0.29/100 SCF of nitrogen gas)

Appendix B

Bayonet Connections

A bayonet is a mechanical connection between two sections of Vacuum Jacketed Pipe that eliminates the need for any welded connections. The bayonet is a low heat inleak device with telescoping male and female components. Due to a close tolerance design, Quality Cryogenics' "low profile" bayonets utilize a metal to metal in-line seal with a silicon O-ring placed between the flanges. These combine to make a reliable heavy-duty cryogenic seal between the two VJP sections, and simultaneously preserves the low heat inleak of the system.



Installation Guide

- 1 Place pipe supports every 10 feet (3 m) and every change of direction.
- 2 Place pipe on supports before engaging bayonets.
- 3 Check alignment and slope of piping. The slope should be up in the direction of flow and 1" (25mm) up for every 50 feet (15.2 m) in length.
- 4 Inspect the male bayonet nose end. It must be clean and free of burrs or damage.
- 5 Wipe bayonet couplings and O-ring with a lint-free cloth.
- 6 Lightly coat the silicon O-ring with a thin film of the supplied lubricant, and place in the groove on the male bayonet.
- 7 Coat the machined nose of the male bayonet with a thin film of the supplied lubricant to prevent galling during installation.
- 8 Engage the male and female bayonets (do not twist) and tighten the V-band to a loose fit. If resistance is felt, re-check alignment and re-engage.
- 9 Continue installing adjacent sections until all are engaged and in place.
- 10 Fine tune support heights to provide a smooth sloping pipe back to the tank.
- 11 When all is in place, tighten V-bands to a snug fit.

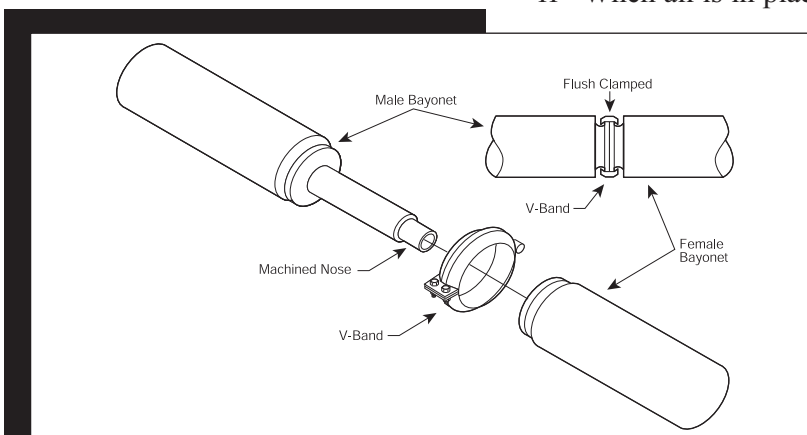

- 12 Finally, visually inspect entire system looking for stress risers and sufficient pipe supports.
- 13 Bayonets that are cold (have been in service) must be warmed to close to room temperature before disengaging. To do this, the VJ pipe must be drained and allowed to warm up approximately 24 hours before attempting disengagement of the bayonets.

Field Joint Couplings

Field joint couplings are vacuum insulated field welded connections between two sections of Vacuum Jacketed Pipe. They have a long heat leak transition between the outer jacket and the inner pipeline to reduce the heat input into the system. After the weld is made, the joint is insulated and a coupling is moved into place over the section. The coupling is then field welded to the collars on the ends of the two piping spools. This coupling is then evacuated to a low vacuum to insure a low heat leak. This type of system is usually installed by Quality Cryogenics' field crew.

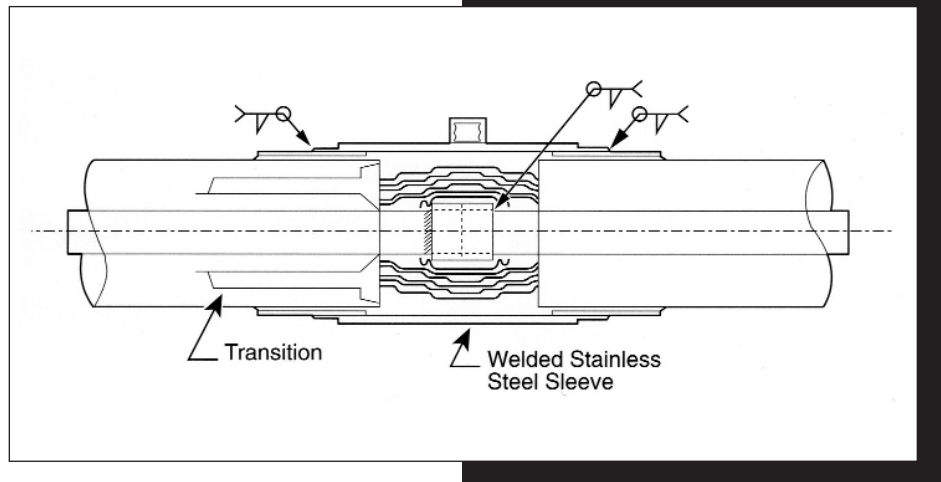

Field Joint Assembly Procedure

Equipment

- ◆ GTAW welding equipment and ASME qualified welder (with qualified procedure) to make a fillet weld on SA-312 Type 304 Stainless Steel pipe
- ◆ Field Joint insulation kit (supplied with VJP section by Quality Cryogenics)
 - Multilayered insulation (paper and foil prewrap)
 - Molecular sieve packages
 - PDO
- ◆ Field Joint assembly kit (supplied with VJP section by Quality Cryogenics)
 - Field joint coupling with pump-out port
 - Socket weld coupling
- ◆ Vacuum Pump
- ◆ Evacuation Fixture
- ◆ Aluminum Tape or Copper Wire

Appendix C

Assembly Procedure

- A. Before welding the VJ Pipe sections together, slide the outer coupling over the end of one section.
- B. Move the two sections together engaging the inner line weld socket.
- C. Weld at the weld socket with an approved ASME procedure.
- D. Appropriately inspect weld to insure a leak proof seal.
- E. Slide the next VJ Pipe section into place and repeat the steps A to D.
- F. If pressure testing is specified, do so now.
- G. Clean and dry the joint area. All parts exposed to vacuum must be clean, free of any oils or solvents, and dry.
- H. Insulate the field joints in the following manner.
 - Attach the sieve packages to the inner pipe (copper wire or aluminum tape). The proper amount of sieve is provided with each kit for each pipe size.
- I. Attach field joint coupling.
 - Slide the coupling over the insulation so that it is centered over the non-insulated area.
 - Weld the coupling to the collars attached to the outer jacket on each side of the joint using an approved ASME procedure.
- J. Attach the vacuum pump operator to the pump-out port, and then evacuate the field joint coupling below 15 microns.

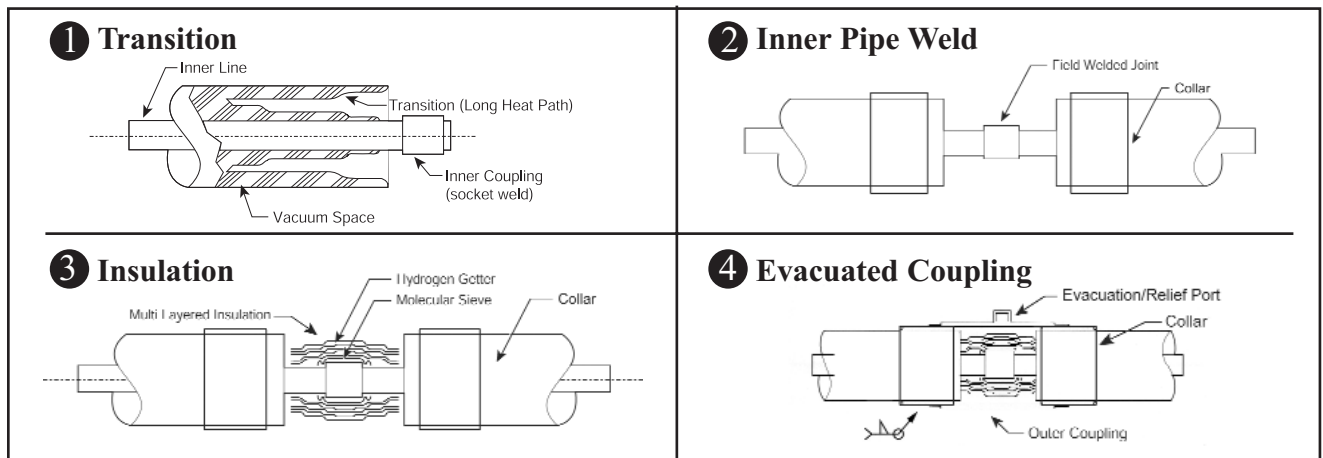

Liquid Nitrogen Distribution System Specifications

Part 1 — General

1.1 Scope

- ◆ The liquid nitrogen storage tank and the Vacuum Jacketed Piping are part of the liquid nitrogen supply system that is designed to store and provide low pressure liquid nitrogen to cryogenic equipment. The piping system is designed to be modular in construction so that it can easily be expanded inside a facility.

1.2 Cryogenic Materials

- ◆ The equipment that is provided is manufactured for use with extremely low temperatures -320°F (-196°C). Any material coming in contact with liquid nitrogen must be either stainless steel, brass, bronze, copper, aluminum, Teflon™, or Kel-F. Any material coming in contact only with cold vapors must be appropriate for extremely low temperatures.

1.3 Related Codes and Standards

- ◆ The equipment that is provided under this specification should be manufactured to the appropriate codes and specification, including but not limited to the following:
 1. Bulk Storage Tanks
 - ASME Section 8, Division 1—unfired pressure vessel. The liquid storage vessel must comply with the latest addendum.

Part 2 — Vacuum Jacketed Piping (VJP) System

- 2.1 The Vacuum Jacketed Piping (VJP) system is designed for the efficient transfer of liquid nitrogen at pressures up to a standard 150 psi (10.34 bar) or greater. The normal operating pressure and the flow requirements are determined by the liquid nitrogen storage tank, and the equipment requirements. Quality Cryogenics is available for consultation on the appropriate sizing of the VJP system.
- 2.2 The VJP system is made up of individual components. These components include VJP sections, cryogenic valves, fittings, and Electronic or Mechanical Keep-Cold assemblies.
- 2.3 Quality Cryogenics VJP is a double walled construction that has an inner pipe for the transfer of liquid nitrogen and an outer pipe to support and retain the vacuum insulation. The inner and outer pipe is constructed with a 300 series stainless steel.
- 2.4 The insulation is a low vacuum with multiple layers of paper and foil (super insulation) applied in such a way as to reflect back radiant heat. Molecular sieves and getters are used with the insulation system to maintain low vacuum levels over a minimum of 10 years.
- 2.5 Thermal contraction of Quality Cryogenics VJP system is accommodated by the inner pipe, so the outer jacket of the pipe system does not require special roller hangers.
- 2.6 The Vacuum Jacketed Pipe sections are designed and built with a factory sealed vacuum and super insulated system. The sections may be connected together with either a mechanical bayonet coupling, or a welded field joint coupling.
- 2.7 An optional thermocouple vacuum gauge and bellow seal isolation valve is used to determine the vacuum level of each section in the field.
- 2.8 Each section will be labeled with a Quality Cryogenics decal giving the name, related drawing number, and the section number of the pipe.

Warranty Vacuum Jacketed Pipe

Quality Cryogenics, the manufacturer of Vacuum Jacketed Pipe, warrants to the purchaser of the Vacuum Jacketed Pipe that the product shall be free from defects in material and workmanship which result in breakdown or failure under normal use for a period of one (1) year from the date of shipment to the original purchaser. Quality Cryogenics also warrants all component plumbing parts for ninety (90) days or manufacturer's warranty if the equipment is used and maintained in a proper manner. Any warranty contained herein shall not apply to any Vacuum Jacketed Pipe which has been repaired or altered outside the manufacturer's facilities or in any way so as to affect its stability or reliability, or which has been subject to misuse, negligence, or accident.

Manufacturer's liability under this warranty shall be limited to the lesser of the repair, replacement, or refund of the purchase price paid by the original purchaser, of equipment that proves to be defective, provided that the original purchaser:

- A. Gives manufacturer written notice within (10) days of discovery of such defect.
- B. Immediately upon discovery of a claimed defect discontinues all use of such equipment.
- C. Returns such equipment freight prepaid to the manufacturer.

Manufacturer shall not be liable for any defects caused by the effects of normal wear and tear, erosion, corrosion, fire, or explosion, and shall not be liable for any special, indirect, or consequential damages incurred by the purchaser as a result of any claimed defect. As a further pre-condition to any manufacturer liability hereunder, purchaser shall return said purportedly defective equipment, freight prepaid, to the plant of the manufacturer. Quality Cryogenics specifically makes no warranties or guarantees, expressed or implied, including but not limited to purpose or use, other than those specified herein. No warranties shall be implied under the uniform commercial code other than warranty of the title.



Quality Cryogenics

425 Gennett Drive

Jasper, Georgia 30143

800-966-6167 (toll-free)

706-692-6167 (worldwide)

706-692-6350 (FAX)

www.vjpipe.com